



U10

Light Commercial & Residential Gas Meter



Gas Series

PRODUCT INFORMATION

The U10 is a light commercial & residential gas meter from EDM's Gas Series. The U10 is rated to 10.0 m³/hr of gas @ 125 Pascal loss across the meter with a high level of accuracy due to its large cyclic capacity, radial valve covers and a magnetic drive which all combine to give superior accuracy retention and stability throughout the life of the meter.



KEY FEATURES



PROVEN
RELIABILITY

AMI

AMI READY



HIGH
ACCURACY



ANTI
TAMPER

U10 Gas Series

Light Commercial & Residential Gas Meter



SPECIFICATIONS

COMPLIANCE

- AS 4647
- EN 1359

CAPACITY

- Gas: 10.0m³/hr (SG 0.64) @ 125 Pa Loss
- Air: 8.0m³/hr @ 125 Pa Loss

ACCURACY

- < ± 1.0% 1.2m³/hr to 8.0m³/hr
- < ± 3.0% @ Qmin

REPEATABILITY

- < 0.2% Typical

PRESSURE RATING

- 25kPa (50kPa Option Available)

CYCLIC CAPACITY

- 2 Litre

PROVEN RELIABILITY

- Low Oscillation and Pressure Loss Characteristic Minimises Wear
- Large Diaphragm Area Provides Increased Driving Force
- Robust Materials - Resistant to Environmental Effects
- Magnetic Index Drive - Superior Leak Tightness

TAMPER RESISTANT

- Security Seal on Body & Index
- Tamper-proof Magnetic Index Drive

ENVIRONMENTAL

- Temperature Range: -10°C to +65°C
- Relative Humidity: Up to 95%
- Corrosion Resistant (AS 2331, 1000hr Salt Spray)
- UV Resistant (AS 4647, EN 1359)
- Ingress Protection: IP55

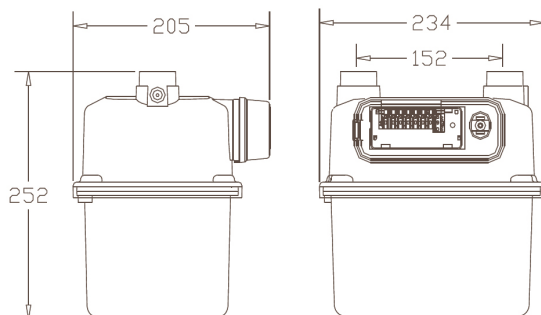

OUTPUT

- Mechanical Metric Index XXXXX.XXX m³
- Pulse-ready Magnetic Output: 1Pulse = 10L
- Tamper-proof Reed Switch Reading Head Optional

PHYSICAL DIMENSIONS

- Connections: 1", 11tpi Thread to BS746 with 6" Centres
- Size: 234mm (W) x 252mm (H) x 205mm (D)
- Weight: Approx. 3.5kg

MATERIALS

- Body: DA401 Diecast with Polyester Powder Coat
- Element: Tern-coated Pressed Steel Body
- Bearings: Moulded Acetal
- Diaphragm: Rubber Moulded with Polyester Reinforcement
- Valves & Grids: Phenolic
- Index Cover: UV Stabilised Polycarbonate
- Gears & Pinions: UV Stabilised Acetal
- Seals: Nitrile
- Links & Arms: Plated Steel

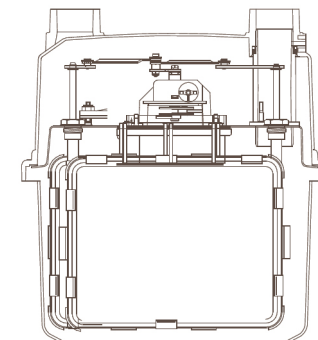
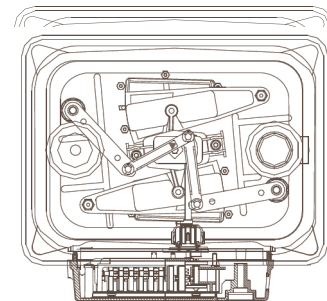

EDMI Limited

47 Yishun Industrial Park A, Singapore 768724
Tel: +65 6756 2938 | Fax: +65 6756 0125
sgmarketing@edmi-meters.com
sgtechsupport@edmi-meters.com

EDMI Gas Pty Ltd

7 Fowler Road, Dandenong, Victoria, Australia 3175
Tel: +613 9794 6000 | Fax: +613 9706 0055
gassales@edmi.com.au

www.edmi-meters.com